

Performance Improvement of Solar Photovoltaic Panel using Smart Water Cooling Technology.

S.Paul¹, N.Mondol², S.Rahman¹, F.Easmin¹ and Moniruzaman¹

¹Department of Energy Science and Engineering, Khulna University of Engineering & Technology, Khulna-9203, BANGLADESH

²Assistant Professor, Department of Energy Science and Engineering, Khulna University of Engineering & Technology, Khulna-9203, BANGLADESH

ABSTRACT

Solar PV panel generates electricity by receiving irradiance from the sun. The amount of electricity generated by a solar panel mainly depends on the intensity of the sunlight and the materials of solar panel. The higher intensity of sunlight, the higher amount of electricity is generated. But with the increasing amount of intensity of sunlight, the surface temperature of the PV panel is also increased. Along with the duration and intensity of sunlight, temperature has also great effect on the efficiency of PV panel. The output of the photovoltaic panel is significantly reduced by the increased amount of temperature above optimal temperature of solar panel. This problem can be solved by using microcontroller based smart water cooling system which decreases the temperature of the PV panel. This decrease in temperature enhances the overall output of the PV panel. By observing the experimental results obtained from solar panel with smart water cooling system and without cooling system, significant improvement in efficiency has been found. The main motive of this work is to maintain the optimum temperature of the PV panel as it gives the best output power at optimum temperature and design a microcontroller base smart controlling system.

Keywords: Solar energy, Panel temperature, Smart water cooler, Efficiency.

1. Introduction

Energy is a must need for life and all living organisms on earth. Due to high consumption of energy continually, the world is facing energy crisis for the limited natural resources. All non-renewable energy will be consumed within next few centuries. Thus renewable energy can be a good alternative of fossil fuels. Among various sources of renewable energy, solar energy is much available and clean which helps to provide enough energy to meet the world's energy demands. Sun generated energy from nuclear fusion which can be used directly or indirectly. Solar energy can be utilized in various application such as in solar collector which converts radiant energy into heat or electricity production using solar cell. Semiconducting materials are used to make solar cells which can generate electricity from the radiation of sun. When sunlight falls on the surface of solar cell, the free electrons are generated which finally produces electricity [1]. The solar PV module cannot convert all irradiance into electricity. The other most of the remaining part of irradiance converts into thermal energy which actually increases the module temperature and reduces the efficiency of solar module [2]. By water cooling system PV module performance can be improved since cooling reduces the excessive heat from the module and maintains the optimum temperature [3]. Circulation of water on the module surface decreases the temperature of PV module by evaporation. Water should not be used directly because of its high conductance property since there is a possibility that it can decrease the efficiency. But this problem can be solved by using distilled water which has lower viscosity and it carries comparatively

high thermal capacity [4]. Therefore decreasing the surface temperature of solar PV module through using thin film of water flowing over the module surface can improve the performance of the solar PV module.

2. Solar Cell Technology

2.1. Solar Irradiance

Along with the temperature, solar irradiance has a great impact on the performance of the solar cells. The word irradiance is termed as the measurement of power density of sunlight received at any location on the earth, which is expressed by watt per meter square (W/m^2). Any changes in solar irradiance can change all the fundamental parameters of any solar cell like the short-circuit current (I_{SC}), open-circuit voltage (V_{OC}), maximum power output (P_m) and efficiency (η) and the fill factor (FF). However the voltage and current both are the function of the solar irradiance falling on the cell. Open circuit voltage and short circuit current increases with the increasing value of irradiance and therefore the maximum power point varies [5]. Though this is true up to a particular value of solar irradiance because at the high value of irradiance temperature of the PV cells comes to play the important role. Due to overheating of the PV cells the overall power output then begins to decrease with the further increase of solar irradiance. Fill Factor and Maximum Power of a PV module are shown Eq. (1) and Eq. (2) respectively

$$\text{Fill Factor (FF)} = I_{mp} \times V_{mp} / I_{SC} \times V_{oc} \quad (1)$$

$$\text{Maximum Power (P}_m\text{)} = I_{SC} \times V_{oc} \times FF \quad (2)$$

* Corresponding author. Tel.: +88-01770139122

E-mail addresses: shovoopaul007@gmail.com, nibir@ese.kuet.ac.bd

Fig.1 which shows the effect of solar irradiance in PV panel I-V and P-V curves. It can be seen that the I-V and P-V curves depend on solar irradiance as the curves are shifting for different value of irradiance.

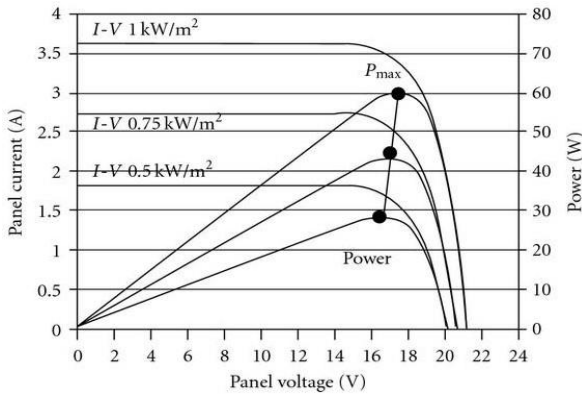

Fig.1 Shifting of I-V and P-V curves for different level of solar irradiance from [5].

It can be seen that the maximum power output (P_m) is increasing with the increase in solar irradiance.

2.2. PV Panel Output

PV panel power output greatly depends on the intensity of sunlight and the module temperature. All incident energy on the solar panel does not convert into electrical energy. Depending on the constructing materials of solar panel, only around 15%-20% of the incident radiation is converted into electrical energy. Rest of the incident energy is dissipated as heat. The panel surface temperature increases due to excessive heat, which actually causes to drop in the performance of the PV panel. Basically PV cell is semiconductor device and like all other semiconductor devices, PV cells are also sensitive to temperature. The efficiency of PV cell is associated with the open circuit voltage (V_{OC}) and the short circuit current (I_{SC}). Increment in surface temperature of solar panel over optimum range causes significant reduction in open circuit voltage (V_{OC}) which results into reduction in the electrical efficiency. Therefore the major resistance to achieve the desired output power from PV panel is overheating the panel due to higher irradiance and higher atmospheric temperature. Maximum operating temperature and the temperature coefficient are being specified by solar cell manufacturer. The P-V curve shows us the relation between the output power P and voltage V , at any constant irradiance and panel temperature. The ideal solar cell (Fig.2) in which diode and current source are connected in parallel position.

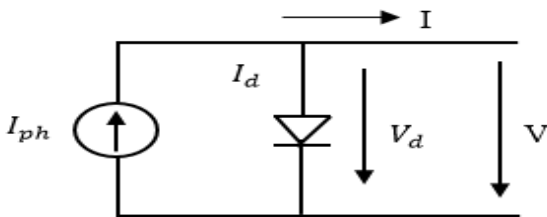

Fig.2 Ideal solar cell model.

Equation of an ideal solar cell, which represents the ideal solar cell model, is Eq. (3)

$$I = I_{ph} - I_s \left\{ \left[e^{\left(\frac{v}{m \times V_t} \right)} - 1 \right] \right\} \quad (3)$$

Where is:

I_{ph} - photocurrent (A), I_s - reverse saturation current (A) ;
 V - diode voltage in volt, V_t - thermal voltage in volt (25.7 mV at 25°C), m - diode factor.

The thermal voltage V_t for given temperature can be calculated with the following equation:

$$V_t = \frac{kT}{e} \quad (4)$$

Where,

k - Boltzmann constant = $1.38 \times 10^{-23} \text{ J/K}$,

T - Temperature (K),

e - Charge of electron = $1.6 \times 10^{-19} \text{ Coulombs}$

The ideal P-V characteristic curves of a solar cell for different temperatures are shown Fig.3,

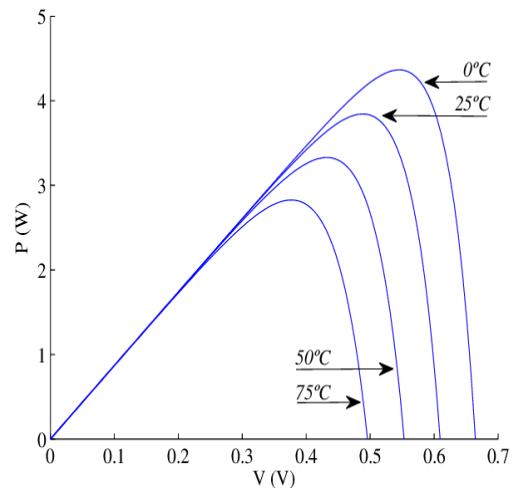

Fig.3 P-V characteristic of solar cell for different temperatures [6].

As it can be seen in Fig.3, with the increase in temperature, the maximum power output is decreasing. It indicates that the output of any PV panels can be affected dramatically with heating of the panels.

3. Design and Experimental Setup of Smart water cooling system

An experimental setup has been developed for this project to study the effects of cooling. Fig.4 shows the setup with a 20W PV module but we are also monitoring 100W PV module, sensors, dc pump, pipe, microcontroller base smart controlling unit etc.



Fig.4 Experimental Setup of components connected with PV module.

A schematic diagram for this project is shown in Fig.5, where all the equipment's such as PV module, charge controller, pump, battery, controller unit, sensors, water tank are shown with connections among them. This is the actual layout of our experimental setup. We have built an android app by which we can control the desired module temperature. We can set our desired module temperature using this app and the controlling will run on that basis.

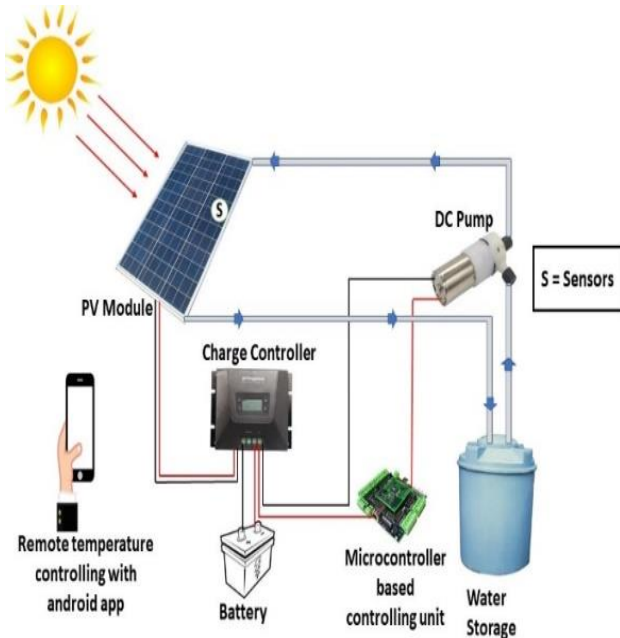

Fig.5 Schematic diagram of PV module with water cooling system.

The circuit diagram of the pump controller and data acquisition system is shown in Fig.6. Following this layout all the components of controlling unit are arranged.

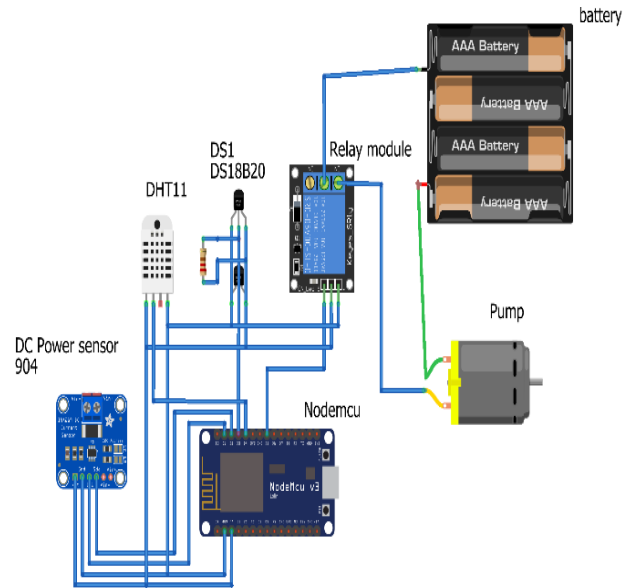

Fig.6 Circuit diagram of pump controller and data acquisition system.

4. Methodology

The solar PV module is a semiconductor device which is made of such types of materials including mono-crystalline silicon, multi-crystalline silicon, amorphous silicon, cadmium telluride etc. When sunlight falls on the surface of PV module then it converts radiant energy into electrical energy by generating free electron-hole pairs.

All essential steps have been carefully followed during the operation of this experiment. Two 20 watts solar PV module have been used for conducting this experiment, one module with cooling system while the other module without cooling system. The tilted angle of PV module was about 23.5° facing due south. In ideal case the optimum temperature for solar PV module is about 25° centigrade. But practically on the basis of geographical location and materials of PV module, this optimum temperature differs. When the temperature rises above this optimum temperature, the output power decreases gradually. So when temperature increases from the optimum value and output power decreases which measures a power sensor and send the signal of the controller after that the cooling system starts automatically. Similarly when temperature decreases below the optimum temperature, output power also decreases. So when temperature starts to decrease below the optimum level then cooling process stops automatically. A timer has been used so that the water cooling cannot be started automatically at night during the very hot weather. Two digital temperature sensors have connected to the PV module. All temperature readings have taken with the help of these digital temperature sensors. These temperature readings have been taken at an interval of 15 minute. In this experiment, the readings for output power, current, voltage have also been obtained at an interval of 15 minute through digital power sensor with their respective temperature reading of solar PV module. All these

features have been controlled smartly by a microcontroller and all the data have been displayed in smartphone which maintained communication with all sensors by internet connection.

5. Result and Data Analysis

Experimental measurements of the module temperature and the efficiency of the PV panel, during April to June 2020, are observed. Following table shows a single day's measurement of our observation.

Table 1 Change in Temperature and Power for Cooling and Without Cooling for along a day.

Time of Day	Panel Temp. Without Cooling (C)	Panel Temp. With Cooling (C)	Output Power Without Cooling (W)	Output Power With Cooling (W)
10:15 am	31	30	15.75	15.90
10:30 am	33	31	16.25	16.50
10:45 am	35	32	16.10	16.95
11:00 am	35	32	16.15	16.99
11:15 am	36	33	16.40	17.13
11:30 am	37	34	16.75	17.58
11:45 am	37	33	17.10	18.45
12:00 pm	39	34	18.17	18.90
12:15 pm	41	35	17.80	19.25
12:30 pm	41	36	16.95	19.55
12:45 pm	43	37	16.47	19.80
1:00 pm	44	37	16.34	19.61
1:15 pm	46	40	16.30	19.12
1:30 pm	47	42	16.28	18.76
1:45 pm	45	40	16.39	18.82
2:00 pm	43	39	16.74	18.65
2:15 pm	44	40	16.70	18.23
2:30 pm	42	37	16.97	17.86
2:45 pm	41	37	17.04	17.74
3:00 pm	40	36	17.10	17.85
3:15 pm	41	36	16.75	18.00
3:30 pm	39	35	16.10	17.75

Table 1 has given the information about module temperature and output power at different time with and without cooling system. From the experimental data it has clearly seen that addition of cooling system increases its output power approximately 1-2 watt.

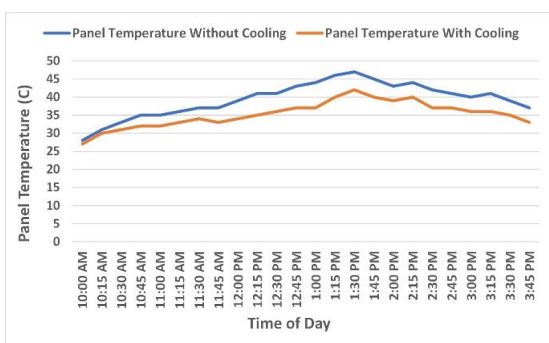

Fig.7 Panel temperature with and without cooling on different times.

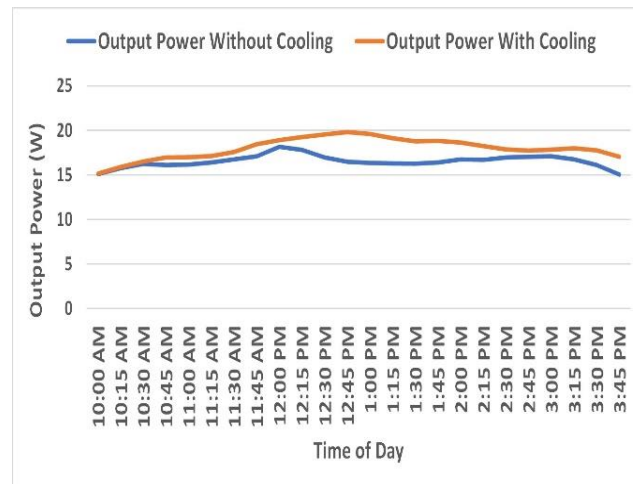

Fig.8 Output power with and without cooling on different times.

Data Analysis:

Without Cooling: The curve from Fig.7, it has been seen that the solar module temperature without cooling is higher than cooling process. The curve from Fig.8, it clearly shows that output power of solar PV module without cooling is less than cooling process.

With Cooling: Fig.7 and Fig.8 has given the respective characteristic curve for temperature and output power of solar PV module with and without cooling process. With cooling process, from Fig.7 it has been shown that the panel temperature increases from 10:00 AM to 1:30 PM but then up to 3:30 PM decreases gradually at a lower level than without cooling process. In Fig.8 the output power has also been followed the same manner as temperature but at a higher level than without cooling process. The maximum output power has been obtained nearly at 12:45 PM because of high irradiance.

6. Cost Analysis

From the experimental data it has been shown that if we use 20W PV module then output power increases average 1.5 watt per hour by cooling process but if we use 100 Watt solar PV module instead of 20W then nearly 60 watt power got in a day. If this power is converted into KWH in a year then it will be 21.9 KWH. The price for this respective unit is about 154 TK in a year. The total cost of propose microcontroller base smart cooling system is Digital temperature sensor – 150 TK, Humidity & Atmospheric Temperature Sensor–120 TK, Pump – 350 TK, DC Adapter – 110 TK, Relay Module – 100 TK, Microcontroller – 500 TK, So the total cost is about 1330 TK. So in this case only 8-9 years will be taken to cover up the cost for additional cooling equipment's. The lifetime of a solar PV module is almost 15 years. So throughout the next 6-7 years, users will be benefitted through cooling process. So the cooling system is applicable and cost effective for large scale or high rated solar PV module and the cost analysis is significant on large scale application.

7. Conclusion

For improving the efficiency of the PV module with water pumping system, smart water cooling technology was developed. The experiment has been completed successfully. This study has showed that at different weather conditions temperature of the panel gets reduced effectively which increases the power conversion efficiency of the PV system. The amount of increased output power by cooling was promising. This increased efficiency meets with the expected result of the experiment. The way of improving output power of solar PV panel by smart cooling is reliable, cost effective and easy to maintain. The smart controlling system which has been implemented in this study is very cheap at cost. Every component used in this smart controlling system is available in the local market and the price of every component is very low. In large scale, the efficiency improvement by cooling will become more significant and economically viable. So it comes to a conclusion that this simple cooling technology can be implemented with any PV module without significant increase in cost.

8. References

- [1] Yogesh S Bijjargi, Kale S.S, Shaikh K.A, "Cooling techniques for photovoltaic module for improving its conversion efficiency: A review", International Journal of Mechanical Engineering and Technology (IJMET) (2016), Volume 7, Article ID: IJMET_07_04_003.
- [2] Swar A Zubeer, H.A. Mohammad, Mustafa Ilkan, "A review of photovoltaic cells cooling techniques", E3S Web of Conferences 22, 00205(2017).
- [3] Nair Milind, Midhun Antony, Febin Francis, Jithu Francis, Joson Varghese, Sajith U K, "Enhancing the efficiency of solar panel using cooling systems", Er.Manoj Kumar. Int. Journal of Engineering and Application (2017), ISSN: 2248-9622, Vol. 7, Issue 3, (Part-4).
- [4] Arjyadhara Pradhan, Dr. S.M Ali, Dr. S.K.S. Parashar, Priyanka Paikray, "Water cooling method to improve efficiency of photovoltaic module", International conference on Signal Processing, Communication, Power and Embedded System (SCOPE) (2016).
- [5] Mohsen Taherbaneh ,A. H. Rezaie, H. Ghafoorifard, K. Rahimi, and M. B. Menhaj, "Maximizing Output Power of a Solar Panel via Combination of Sun Tracking and Maximum Power Point Tracking by Fuzzy Controllers", International Journal of Photoenergy, Volume 2010
- [6] Rodrigues EMG, Mel'cio R, Mendes VMF, Catala'õ JPS. "Simulation of a solar cell considering single-diode equivalent circuit model." International conference on renewable energies and power quality, Spain, 13–15 April, 2011.
- [7] R. Messenger and H. A. Abtahi, Photovoltaic Systems Engineering. CRC Press, Taylor & Francis Group, 2017.
- [8] N.Mondol, M.R.I. Sheik, Rakibul Hasan "Stabilization of Wind Firm Integrated Hybrid Power System by Using STATCOM" IEEE co-

Sponsor, 1st International Conference on Electrical & Electronic Engineering (ICEEE), 4-6 November, 2015, EEE, RUET, Rajshahi, Bangladesh.

- [9] M.R. Salem, M.M. Elsayed, A.A. Abd-Elaziz, K.M. Elshazly "Performance enhancement of the photovoltaic cells using Al₂O₃/PCM mixture and/or water cooling-techniques" International Journal of elsevier, Renewable Energy 138 (2019) 876-890, Accepted 7 February 2019 Available online 10 February 2019.

